

SECTION 1
3/4"=1'-0" S-4

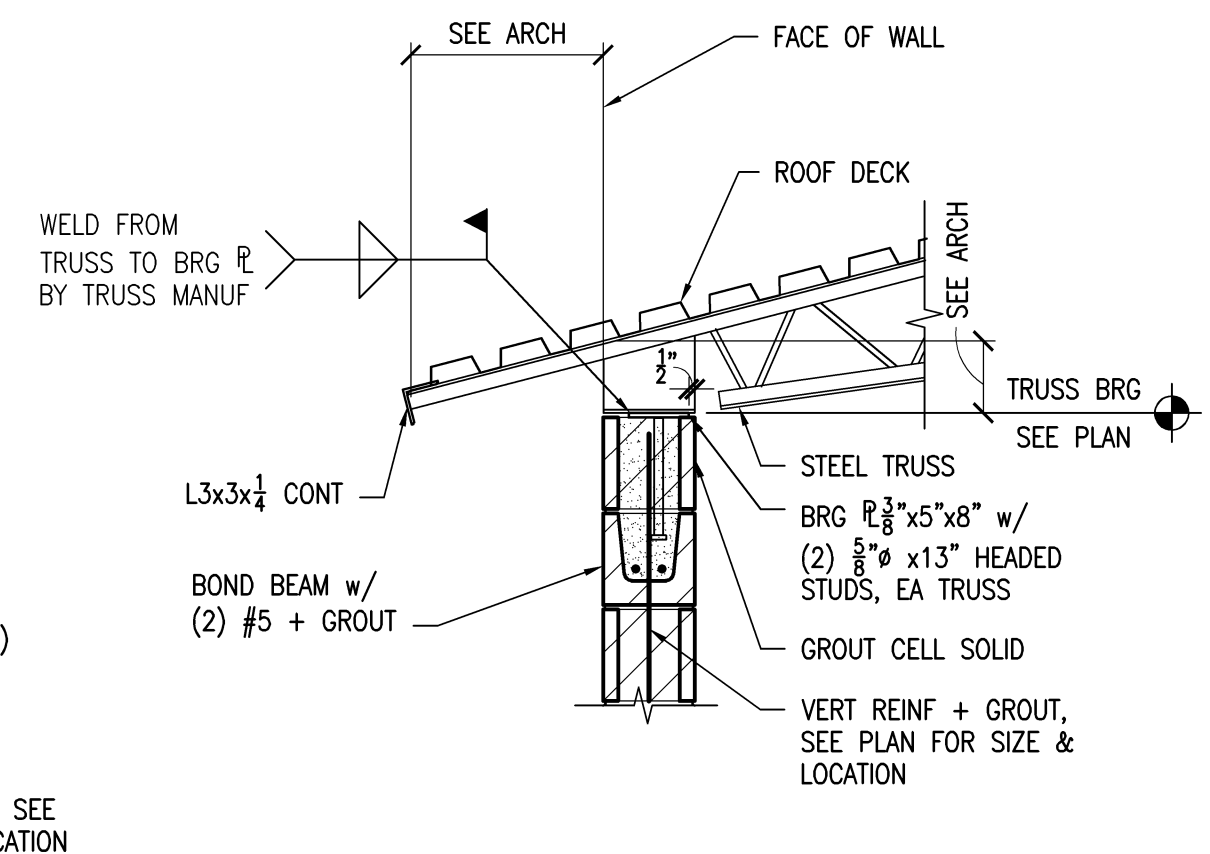

SECTION 2
3/4"=1'-0" S-4

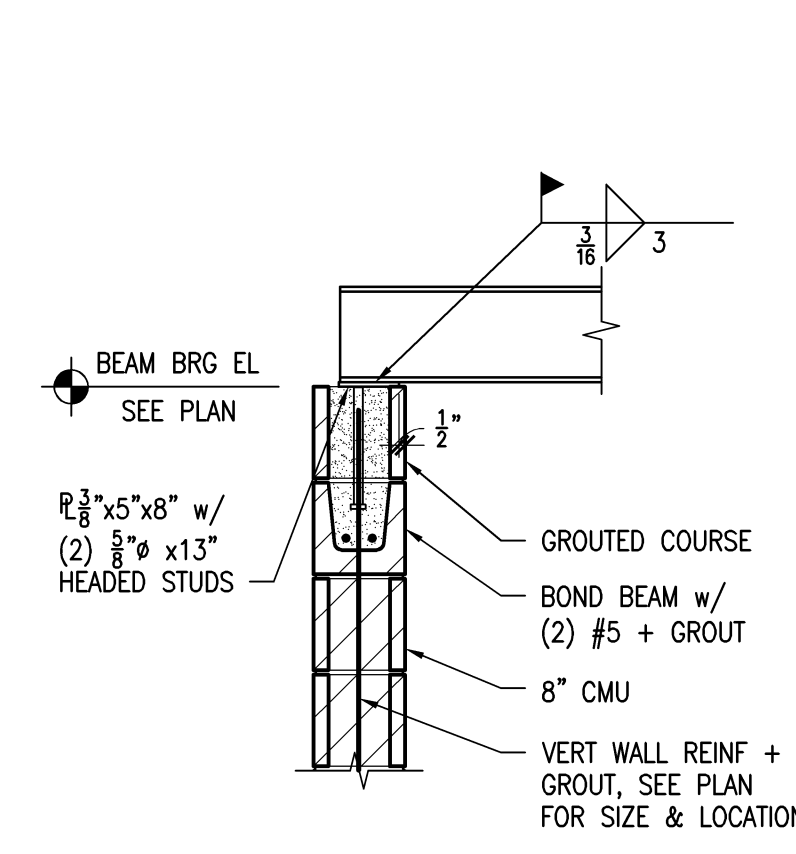

SECTION 3
3/4"=1'-0" S-4

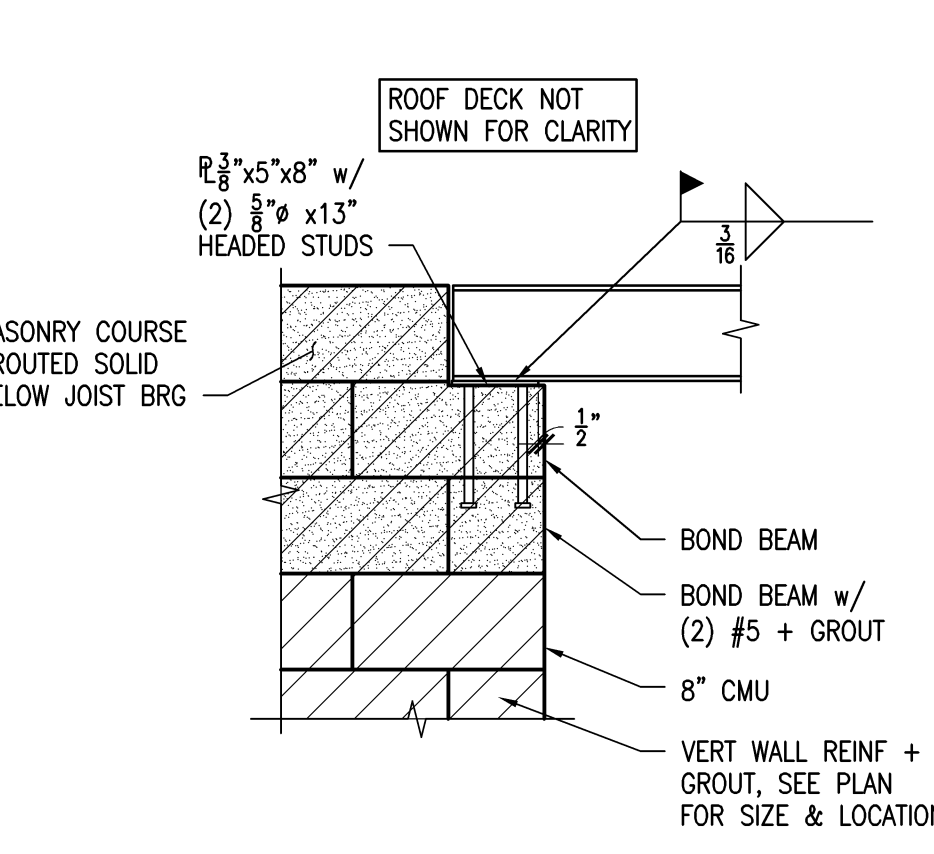

SECTION 4
3/4"=1'-0" S-4

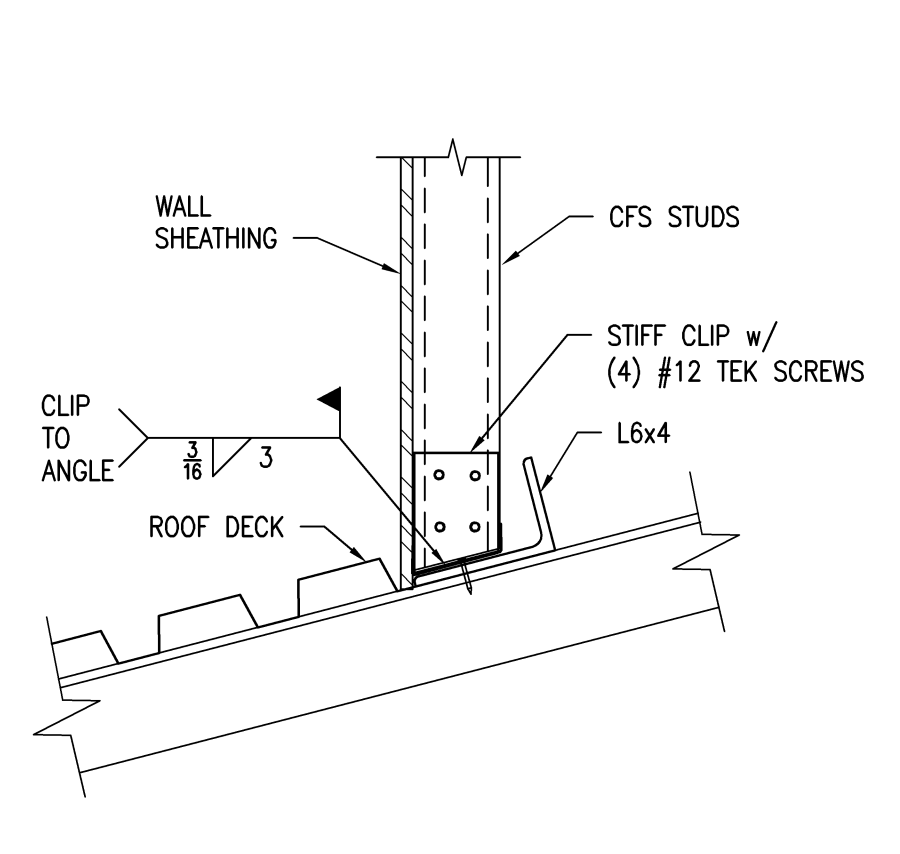

TYPICAL COLD FORMED
STEEL HOLDDOWN
1 1/2"=1'-0"

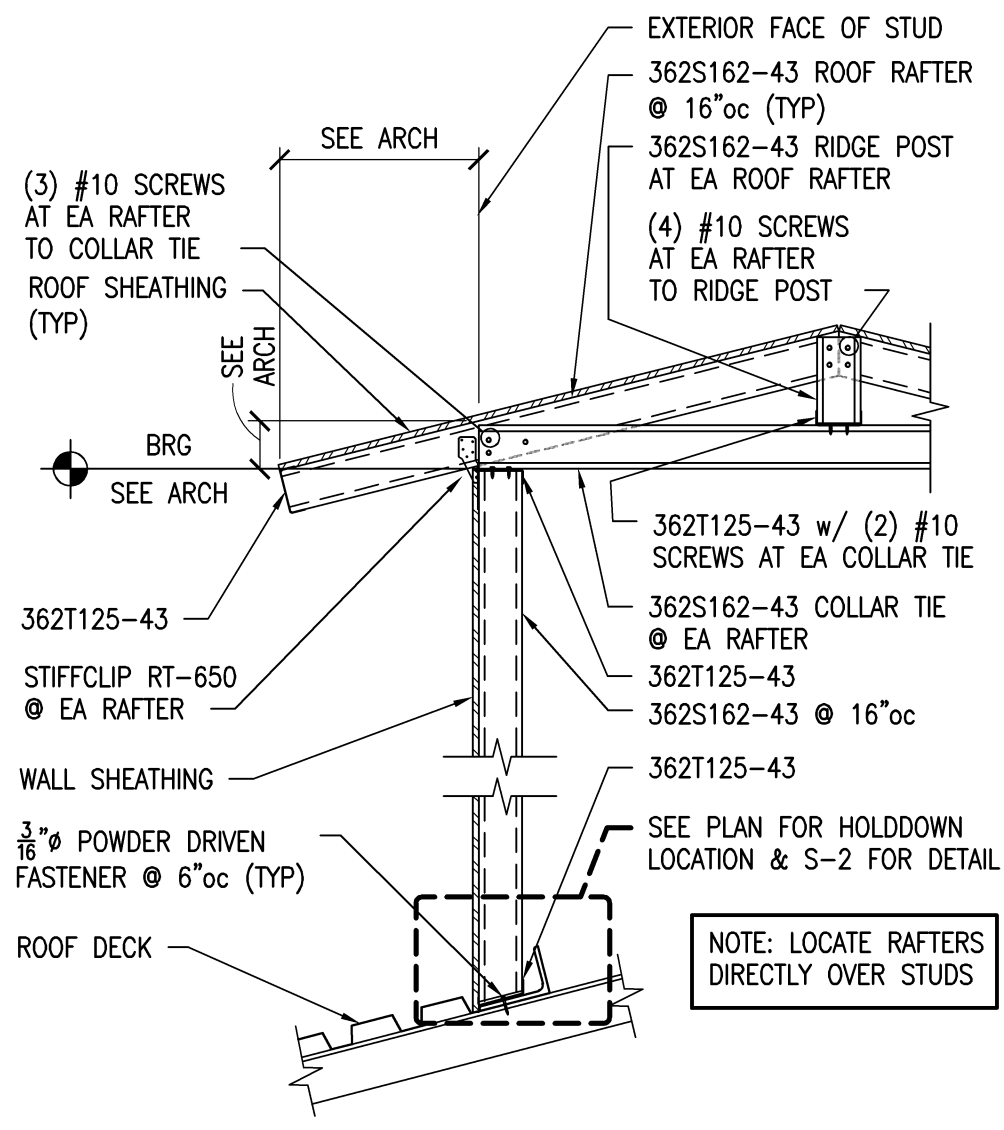

SECTION 6
3/4"=1'-0" S-4

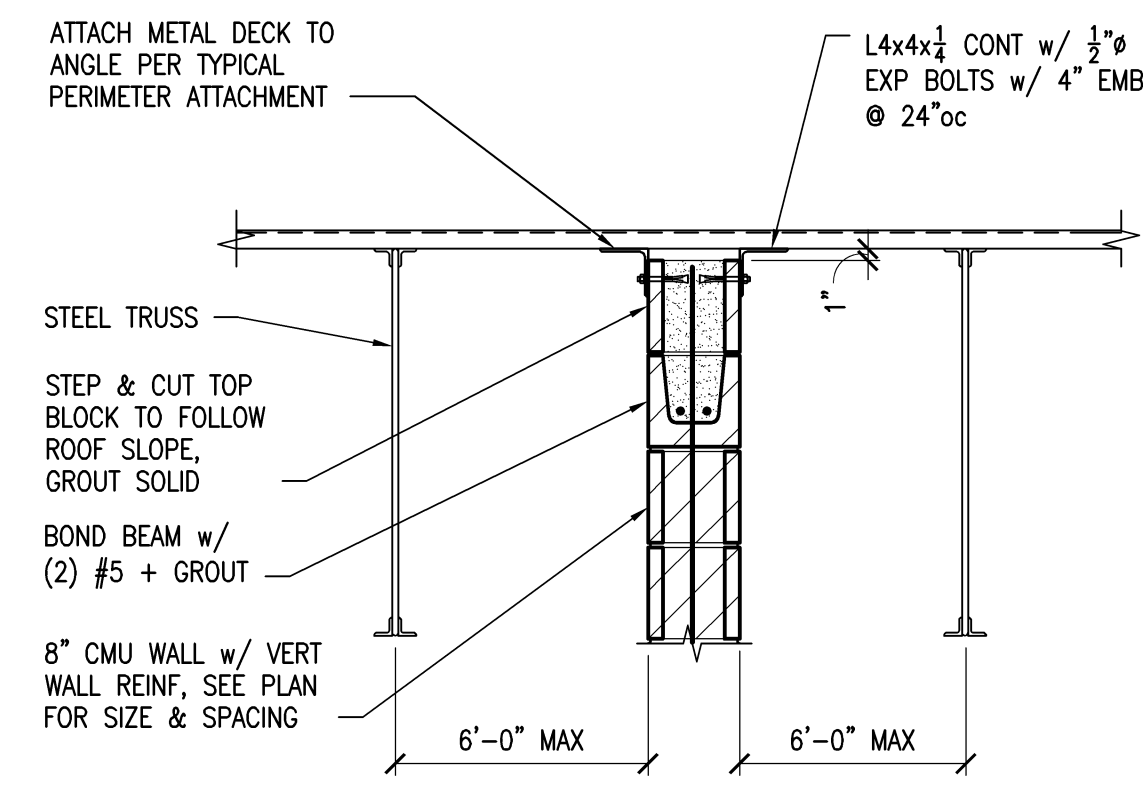

SECTION 7
3/4"=1'-0" S-4

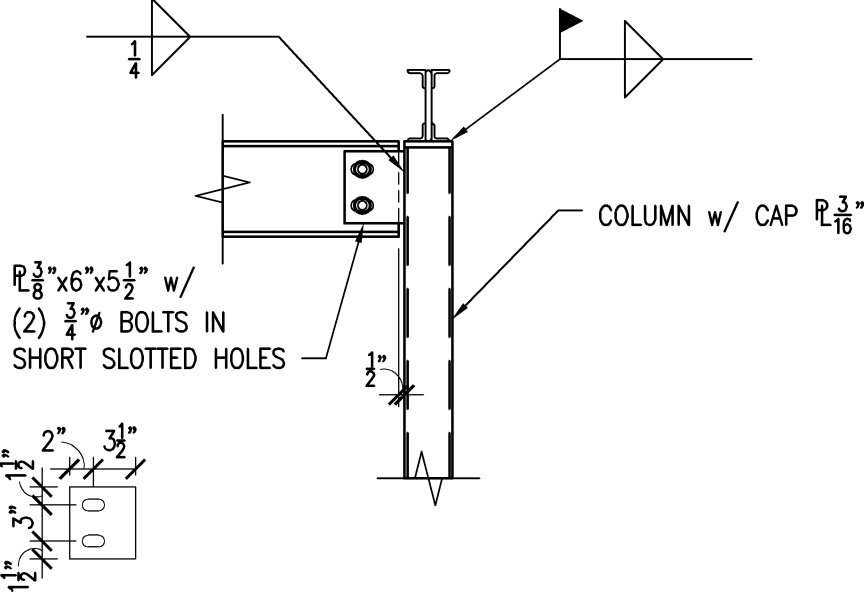

SECTION 8
3/4"=1'-0" S-4

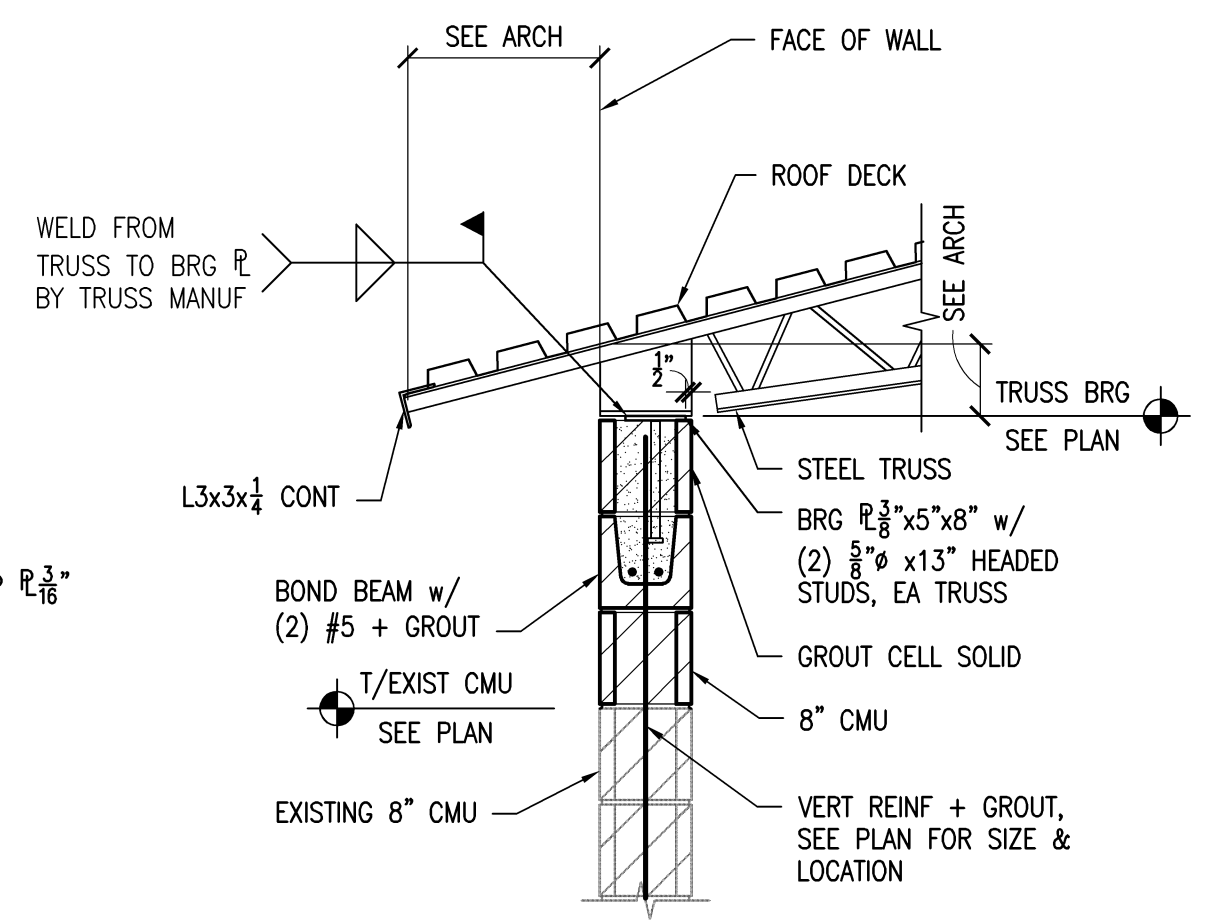

SECTION 9
3/4"=1'-0" S-4

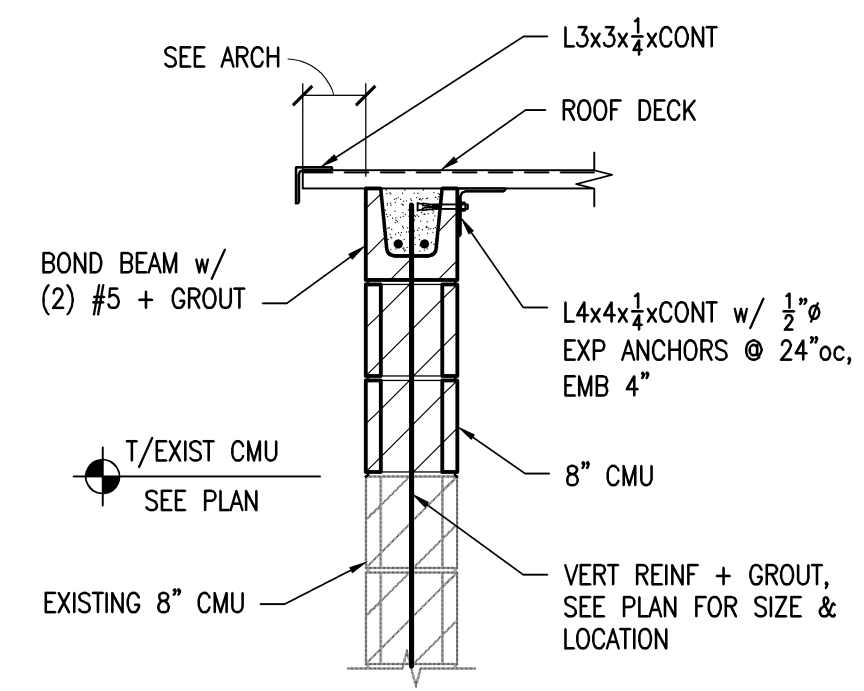

SECTION 10
3/4"=1'-0" S-4

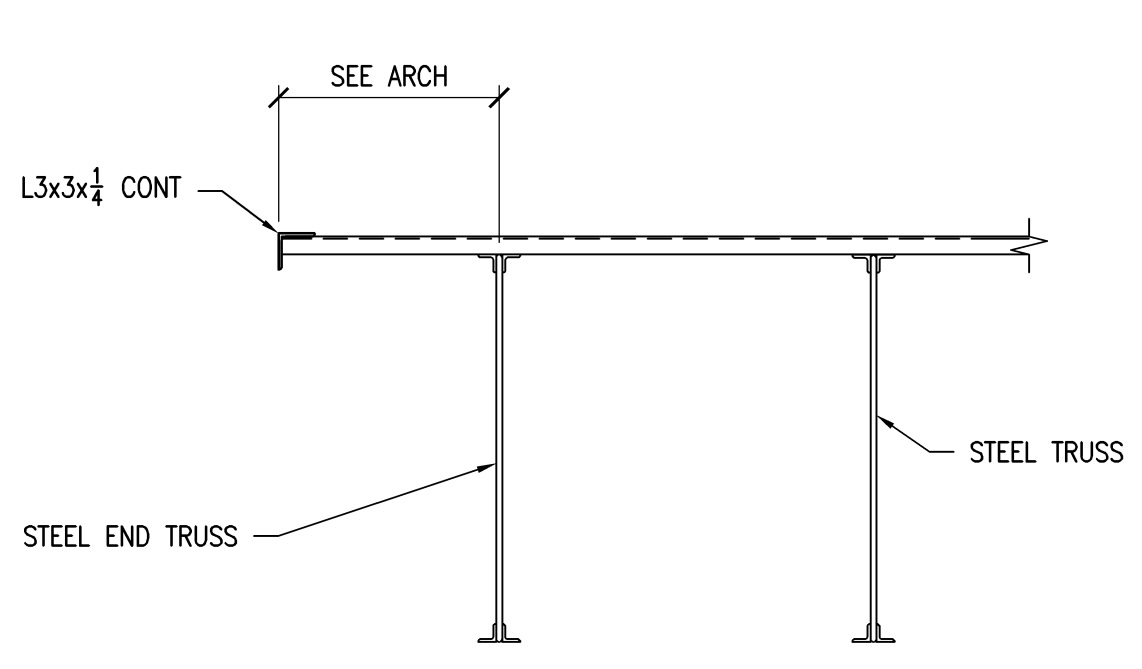

SECTION 11
3/4"=1'-0" S-4

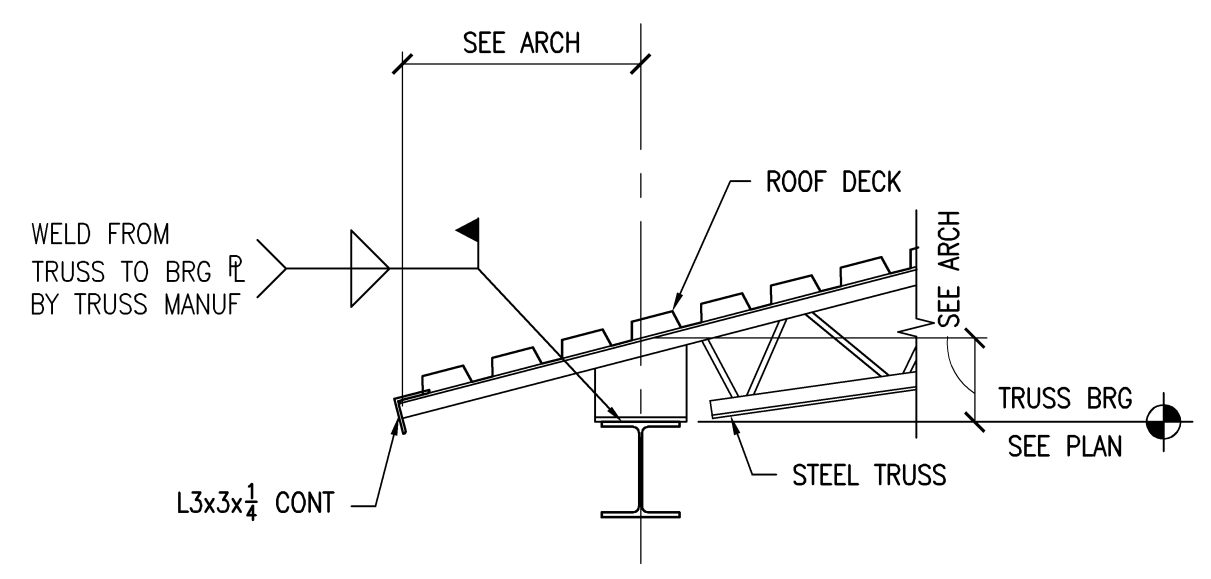

SECTION 12
3/4"=1'-0" S-4

SHEAR WALL SCHEDULE						
1 FRAMING & SHEATHING						
MARK	WALL SHEATHING	FASTENER TYPE AND SPACING AT WALL PANEL EDGES	FASTENER TYPE AND SPACING WITHIN WALL PANEL FIELD	BLOCKING STUDS TO MATCH WALL STUDS	HOLDDOWN ((1) EA END OF SHEARWALL)	NUMBER OF STUDS EA END OF SHEARWALL
1	7/16 APA RATED SHEATHING ONE SIDE	#10 SELF-DRILLING TAPPING SCREWS @ 4"oc	#10 SELF-DRILLING TAPPING SCREWS @ 12"oc	YES	SEE SHEET S-3 FOR HOLDDOWN DETAIL	(2)

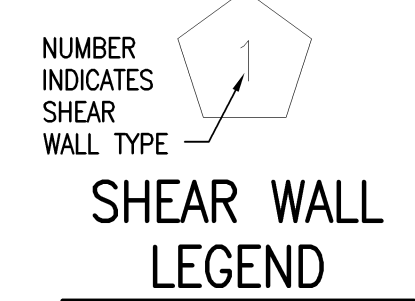

CFS HEADER SCHEDULE				
MARK	HEADER SIZE	BEARING STUDS BOTH ENDS	END STUDS BOTH ENDS	HOLDDOWN CONNECTOR OF HEADER TO BEARING STUDS
H1	(2) 362S162-43	(1) 362S162-43	(2) 362S162-43	SIMPSON LTS12

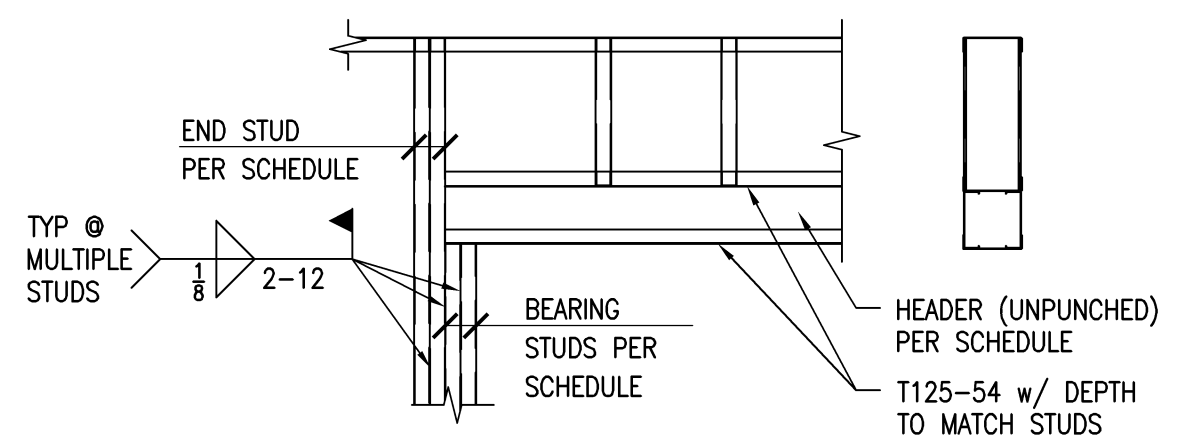

CFS MEMBER DESIGNATION		
FLANGE WIDTH IN 100TH OF AN INCH (E.G., 200 = 2")	MEMBER DEPTH IN 100TH OF AN INCH (E.G., 362 = 3 6/8")	MATERIAL THICKNESS IN 1000TH OF AN INCH
162 = 1 6/8"	400 = 4"	S = STUD OR JOIST
150 = 1 1/2"	600 = 6"	T = TRACK
50 = 1/2"	800 = 8"	U = CHANNEL
	1000 = 10"	F = FURRING CHANNEL
	1200 = 12"	
		33 = 20 GAGE
		43 = 18 GAGE
		54 = 16 GAGE
		68 = 14 GAGE
		97 = 12 GAGE

FRAMING SECTIONS
HIDDEN VALLEY POOL HOUSE
19308 Scharr Drive
Lawrenceburg, IN 47025

Steven Schaefer Associates, Inc.
Consulting Structural Engineers
1001 N. Main St., Suite 101, Columbus, IN 47301
Phone: 317-852-3300, 800-543-3102 Fax: 317-852-5400
www.stevehsc.com

DATE: 09/13/2011
PROJECT: MJM/GJB
DRAWING NO.: 1118.55
FILE: 01fp1865.dwg

REVISIONS: 09/13/2011 PERMIT

0 S-4 OF 0

Plot Date: Sep 13 2011 3:59PM, File Name: 01fp1865.dwg, Plotted By: kcm

COPYRIGHT © 2011
THIS DOCUMENT IS THE PRODUCT AND EXCLUSIVE PROPERTY OF STEVEN SCHAEFER ASSOCIATES, INC. NEITHER THE DOCUMENT NOR THE INFORMATION IT CONTAINS MAY BE COPIED OR USED FOR OTHER THAN THE SPECIFIC PURPOSE FOR WHICH IT WAS PREPARED, WITHOUT THE WRITTEN CONSENT OF STEVEN SCHAEFER ASSOCIATES, INC.